



products & solutions

Protection Screens



Disability Range





company



Company Info

Savekers Ltd



Our Solutions

With an enviable pedigree and heritage, together with more than 100 years as an established specialist in quality manufacturing, Savekers Ltd offers a level of production and service unrivalled in our field.

Building on the strengths and resource of the founding company, T Saveker Ltd, and through acquisitions and product diversification, we aim to provide an ever-evolving level of customer support through exceptional customer service and skilled bespoke and standard product manufacture.

All aspects of the Company and the skills within, join to collectively meet customer requirements across a range of disciplines and market sectors. These include shopfittings, POS, internet & IT solutions, metalwork, joinery, commercial & business support.

Metalwork Manufacture

Whether the requirement is for standard or bespoke products, for various applications, we are positioned to provide unrivalled products and solutions across a diverse range of architectural metalwork materials and finishes.

Alongside our specialist CAD technical design team, is our comprehensive 45,000 square foot production facility, which spans water jet cutting, CNC machining, NC bending, welding, polishing, general fabrication, anodising and chrome plating.

Our ever-growing portfolio of architectural metalwork products, recognised as one of the most comprehensive in the UK, provides solutions for local authorities, the retail sector, exhibitions, financial institutions, leisure & entertainment, construction – to name but a few.



Joinery Manufacture

As a specialist in the design and manufacture of high quality, stylish bespoke woodworking solutions, we are able to produce functional and beautifully crafted designs across a range of uses, applications and sectors.

Our team of skilled craftsmen are experienced in working with all types of wood - solid wood, real wood, veneer, laminate, and to incorporate glass, metalwork, or solid-surfacing. Furthermore, we operate a strict process of traceability to ensure that we only purchase timber from sustainable forests by sourcing material from registered environmentally friendly sources. Whatever the project nature or size, we will work from existing designs or through working closely with customers, to produce new designs utilising our established in-house CAD designers and facilities. Solutions may include timber reception desks, bars, counters, cabinets, storage units, POS and retail display shelving and furniture.

t +44 (0)121 331 1903
f +44 (0)121 331 1900
e info@savekers.com
w www.savekers.com

Please refer to our standard Terms & Conditions.
Visit our website or contact us for a copy.

Savekers Limited
101 Aldridge Road, Perry Barr,
Birmingham, B42 2TS,
United Kingdom



products



Contents

Protection Screens & Disability Range



Protection Screens

Our protection screens have been tested by the Post Office network to meet its own physical attack and installation requirements when installed with a suitably tested counter base.

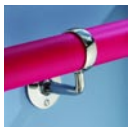

Disability Range

Our disability range has been designed with the help of Disability Access Charter to meet the needs of people with disabilities and to comply with Section M of the Building Regulations 1991.

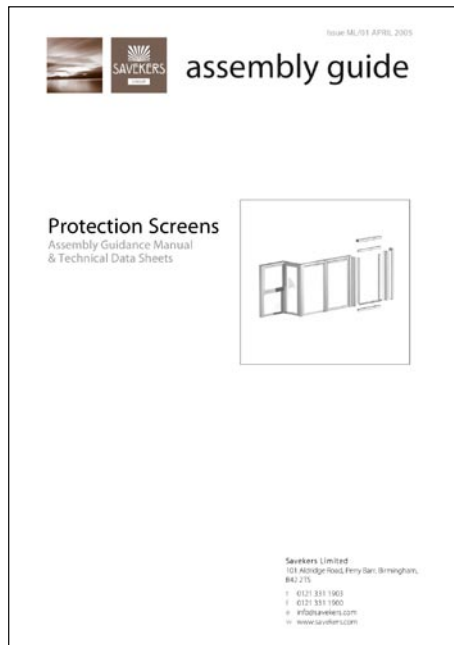
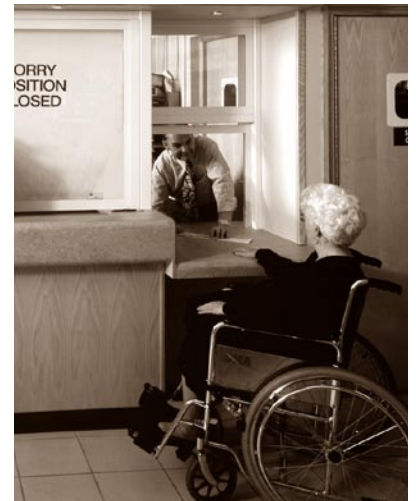

A detailed assembly guide is available from our website: www.savekers.com

Related Product Ranges

- Retail Systems
- Pedestrian Guidance & Barriers
- Balustrading & Handrails
- Leisure Range

Many of the products illustrated can be manufactured to customers' specific size and finish requirements. As manufacturers, we are happy to quote against specific requirements on receipt of sketches or drawings.

An on-line catalogue of standard products can be found on our website.

Please also refer to our standard Terms & Conditions. We reserve the right to amend designs and products without prior notification.

Please refer to our Cleaning & Maintenance Guidance sheet.

t +44 (0)121 331 1903
 f +44 (0)121 331 1900
 e info@savekers.com
 w www.savekers.com

Please refer to our standard Terms & Conditions.
 Visit our website or contact us for a copy.

Savekers Limited
 101 Aldridge Road, Perry Barr,
 Birmingham, B42 2TS,
 United Kingdom



products



Protection Screens

Fixed Panels, Service Positions & Parcel Hatches



Protection screens meet the Post Offices physical attack and installation requirements.



H513



Protection screen installation

Tested by the Post Office network to meet physical attack and installation requirements when installed with a suitably tested counter base.

Savekers protection screen is suitable for any location where cashiers or staff need added security. The screens are widely used in post offices, insurance offices, kiosks, local government offices, police stations, late night stores and payment offices. The screen can be supplied to suit almost any location. 90° Corners or recesses can be accommodated as can varying heights and widths. The units are bolted through the counter and there are no customer side fixings.

For additional security top fixings are provided and a steel bar can be inserted inside the upright sections. The system accepts glass panels 10mm to 14mm thick. A secondary stainless steel framework is supplied to bond around the glass giving extra strength and speedier fitting. Please note when used with the stainless steel framework the maximum glass thickness is 12mm. The whole screen is easy to fit thus saving time and money. Parcel hatches can be incorporated while still retaining security. The hatch is easy to operate using only one hand leaving the other free to accept the parcel. A ratchet prevents the hatch being forced up from the public side of the screen while allowing staff to close the hatch instantly in the event of a security problem.

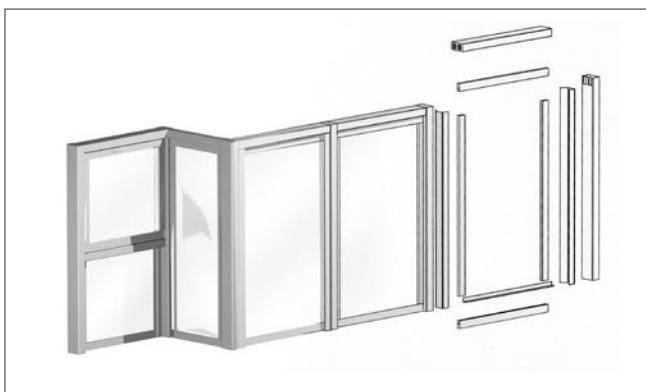

Example configuration for a protection screen installation.

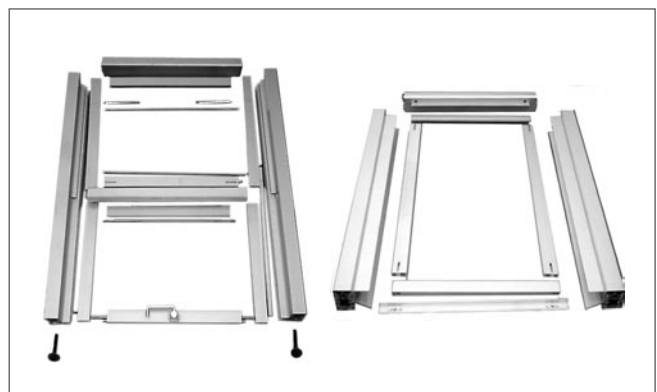

Sample of protection screen components.

t +44 (0)121 331 1903
 f +44 (0)121 331 1900
 e info@savekers.com
 w www.savekers.com

Please refer to our standard Terms & Conditions.
 Visit our website or contact us for a copy.

Savekers Limited
 101 Aldridge Road, Perry Barr,
 Birmingham, B42 2TS,
 United Kingdom



products



Protection Screens

Screens & Accessories



H513 Lowered counter and parcel hatch to provide counter service for wheelchair users.



Screen used in conjunction with coin scoop.



H517

Service points incorporate a protective section which conceals the sound passage between glass and framework and allows conversation to take place safely. A selection of stainless steel coin scoops and transfer trays is available to fit into the counter beneath the screen.

H325 Security transfer tray 300mm x 300mm x 120mm overall depth. Requires cut out 285mm x 285mm.

H513 Security screen to protect staff from threatening behaviour and physical attack.

H517 Parcel hatch can be fitted into a suitable security door. Ideal for locations where limited space prevents a parcel hatch being incorporated into a screen.



H166



H187



H325

An attractive streamlined appearance is achieved by the use of extruded aluminium materials for all the sections. These are then etched and anodised to enhance the smooth and unobtrusive lines of the screen. The system can also be powder coated in a wide choice of available colours. The major benefits of this system are:

- Attractive appearance
- Solid construction
- Ease of fitting
- Security provided
- Peace of mind ensured

Technical literature and installation details available on request.

H166 Coin scoop 280mm wide, 250mm front to back x 45mm overall depth. Requires cut out 255mm x 224mm.

H187 Cash transfer tray 250mm wide, 350mm front to back x 90mm overall depth. Requires cut out 240mm x 340mm.

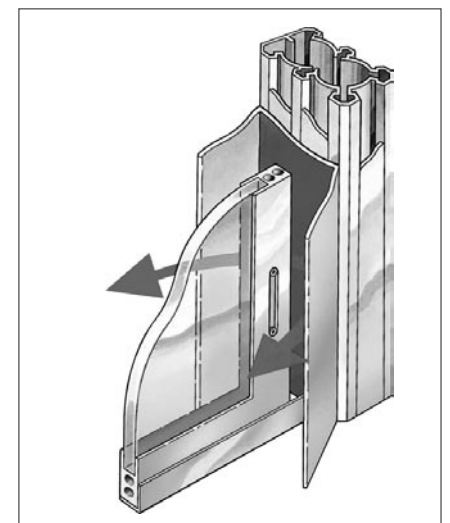

Cross Section of Protection Screen Service Point

t +44 (0)121 331 1903
 f +44 (0)121 331 1900
 e info@savekers.com
 w www.savekers.com

Please refer to our standard Terms & Conditions.
 Visit our website or contact us for a copy.

Savekers Limited
 101 Aldridge Road, Perry Barr,
 Birmingham, B42 2TS,
 United Kingdom



products



Disability Range

Rail Systems & Accessories



Disability Rail System



H561

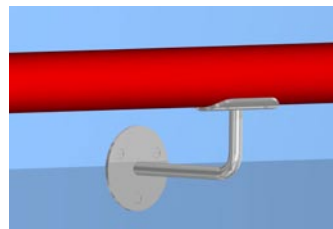

H1596

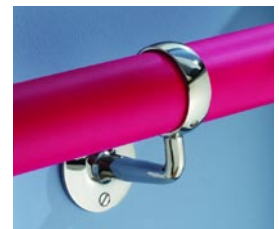

H1817



H740



H722 / H616



H1816



H1812

The following products have been designed with the help of Disability Access Charter to meet the needs of people with disabilities and to comply with Section M of the Building Regulations 1991. The non-slip grip used on these products is available in three colours to provide contrast against background colours for those with visual disabilities. The grip is suitable for use across a wide temperature range and can be used both inside and outside. Most items are supplied in a satin stainless steel finish.

H249 Tube. 16 gauge available in various diameters and finishes. Most diameters and finishes can be bent to your requirement.

H561 Special angle bend to any angle in tube supplied with liner joints. Can be supplied with non-slip, warm feel grip in red, yellow or blue on larger radius bends. Polished Brass. Chrome. Satin Chrome. Stainless Steel.

H722 Drop end. Customer to specify angle when ordering. Requires H616 end cap. Polished Brass. Chrome. Satin Chrome. Stainless Steel.

H740 Adjustable elbow. Allows special angles from 90° to 180° to be created on site. Also suitable to create a change in plane up to 25mm. Polished Brass. Chrome. Satin Chrome.

H1596 Cranked handrail bracket with saddle top for tube fitted with non-slip grip. 90mm centreline projection from wall, 63mm diameter fixing plate. Polished Brass. Chrome on Brass. Satin Chrome.

H1812 Floor to ceiling support rail. From stainless steel tube fitted to floor and ceiling with chrome on brass flanges. With non-slip, warm feel grip in red, yellow or blue this rail is suitable for internal or external use. Up to 2.5mm high or other heights made to order.

H1816 Pivot base barrier post for ramp. Fully adjustable to enable a barrier/handrail to be fitted to most ramps without the need for special measuring and manufacture. Polished Brass. Chrome. Satin Chrome. Stainless Steel Powder Coated.

H1817 Through ring cranked handrail bracket to accept tube with non slip grip. 90mm centreline projection, 63mm diameter fixing plate. Polished Chrome on Brass. Satin Chrome.



H1812

t +44 (0)121 331 1903
 f +44 (0)121 331 1900
 e info@savekers.com
 w www.savekers.com

Please refer to our standard Terms & Conditions.
 Visit our website or contact us for a copy.

Savekers Limited
 101 Aldridge Road, Perry Barr,
 Birmingham, B42 2TS,
 United Kingdom



products



Disability Range

Rail Systems & Accessories



H1811



H1814



H1815



H1811 (shown with optional cover plate)



H1813



H1815 (shown in up position)

H1811 Support rail. From stainless steel tube with 76mm diameter fixing plates and optional cover plates. With non-slip, warm feel grip in red, yellow or blue this rail is suitable for internal or external use. 600mm long over centres, 50mm projection from wall or other sizes made to order.

H1813 Cranked support rail. From stainless steel tube with 76mm diameter fixing plates and optional cover plates. With nonslip, warm feel grip in red, yellow or blue this rail is suitable for internal or external use. 300mm x 300mm, 50mm projection from wall or other sizes made to order.

H1814 Extra projection support rail. From stainless steel tube with 76mm diameter fixing plates and optional cover plates. With non-slip, warm feel grip in red, yellow or blue this rail is suitable for internal or external use. 400mm long, 250mm projection from wall or other sizes made to order.

H1815 Hinged support rail. From stainless steel tube with 102mm x 111mm stainless steel back plate. With non-slip, warm feel grip in red, yellow or blue this rail is suitable for internal or external use. 750mm projection.

H1818 Non-slip, warm feel grip in, red, yellow or blue fitted to handrail tube. Suitable for internal or external use when used with non ferrous tube and fittings.

H1818 Non Slip Grip Colour Options



t +44 (0)121 331 1903
 f +44 (0)121 331 1900
 e info@savekers.com
 w www.savekers.com

Please refer to our standard Terms & Conditions.
 Visit our website or contact us for a copy.

Savekers Limited
 101 Aldridge Road, Perry Barr,
 Birmingham, B42 2TS,
 United Kingdom

Ranges Available



Sliding Door & Window Track

A range of sliding glass door track systems for either 6mm or 10mm glass.



Retail Systems

Flexible and interchangeable options for POS, storage and product display.



Counters, Cabinets & Fittings

Full display units through to accessories and complementary components.



Shelving Systems

Unobtrusive and flexible solutions for display and storage purposes.



Pedestrian Guidance & Barriers

Functional and durable systems providing solutions for queuing and restricting access.



Balustrades & Handrails

Floor fixing and side mounted balustrading systems and co-ordinating handrails and accessories.



Leisure Range

Traditional and contemporary products and furniture designed for hotel and leisure sectors.



Disability Range

A range of fittings and accessories in compliance with the DDA 2004.



Door Furniture & Window Guards

Providing decorative and practical solutions in a variety of finishes and design themes.



Protection Screens

Protection Screen systems that provide appropriate security when cashiers or staff require it.

Please contact our Sales team for further information, technical assistance or to discuss any requirements.

Savekers Limited

101 Aldridge Road, Perry Barr, Birmingham, B42 2TS United Kingdom

t +44 (0)121 331 1903 f +44 (0)121 331 1900 e info@savekers.com w www.savekers.com